

# Laddomat 22<sup>®</sup> Laddningspaket

User manual

Laddomat 22 / Laddomat X22 - 1 / Laddomat X22 - 2



Laddomat 22  
recommended to 100 kW



Laddomat X22 - 1  
recommended to 50 kW



Laddomat X22 - 2  
recommended to 50 kW

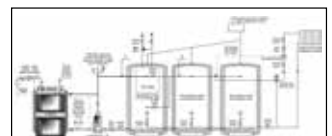
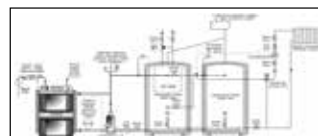
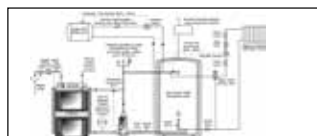
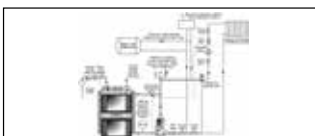



# Laddomat 22<sup>®</sup> Laddningspaket

## Installation Manual

### CONNECTION

The **Laddomat 22** must always be connected in the upright position as shown in the diagrams. Place the Laddomat 22 near the boiler and at the level of the return pipe to the boiler. The pipeline must be as short as possible and have the minimum number of bends. The system must be constructed so that air pockets are avoided in any part. The diameter of the pipe from the top of the boiler down to the Laddomat 22 must be as large as possible. This ensures low water velocity and allows perfect air release in the boiler to separate out in the expansion chamber or the vent.

To fill the heating system, always use the lower connections on storage tanks or boiler.

### VENTING

The air in the heating system is in nine cases out of ten the cause of all malfunctions.

For the system to work, the pipes must be installed so that the air releases spontaneously from the system.

Higher positions in the system must be equipped with the venting. Different kinds of water have a different ability to bind the air that is released when the boiler is heated. See special instructions „Important at startup“.

### EXPANSION VESSEL

If in spite of all the measures the malfunctions related to the air locking occur, you need to check: the expansion vessel - it should have a sufficient volume.

- at the open expansion, the volume must be at least 5 to 10 % of the total volume of water in the heating system.

- at the pressure expansion, the volume must be at least 10 to 20 % of the total volume of water in the heating system.

With regard to the system and manufacturer's recommendations, it is necessary to consider each system separately.

### WIRING

The Laddomat 22 pump is connected so that it runs shortly after the firing and stops shortly after the fuel burnout to minimize losses in the idle mode. See the User Manual.

Some boilers have a built-in flue thermostat which can control the circulation pump on the Laddomat 22. This is ideal when connecting the boiler with storage tanks. To switch on the pump on the Laddomat 22 for boilers connected without use of storage tanks, use the thermostat cartridge located at the outlet of the boiler or the pump thermostat built in the boiler (70 - 80 °C).

### DIMENSIONING

At boiler outputs up to 30 kW the pipe diameter of the circulating loop at top of the boiler (riser) and at bottom of the boiler (return) should be at least R 25 or Cu 28. At the boiler output from 30 to 50 kW, R 32, Cu 35 or greater need to be used at least.

At the boiler output over 50 kW, R40 or Cu 42 need to be used as a minimum.

At the boiler output over 100 (120) kW, R50 or Cu 54 need to be used as a minimum.

In the case of special requirements for the self-circulation, the pipe diameter is proposed according to these requirements.

### THERMOSTAT CARTRIDGE

The thermostat cartridge is available as a spare part and needs to be replaced if it was regularly exposed to high temperatures close to or above the boiling point.

The number is engraved on the body.

Number    Opening temperature

1456\*    78 °C - this is used during the normal operation (factory fitted)

8719\*    72 °C - this is used at start-up and at boilers with a high output; (spare - included in the package)

1467    83 °C

8222    87 °C

\* Included in the delivery

## SERVICE

Before carrying out any servicing work, always close the three shut-off valves by turning the lever on the valves at right angles to the direction of the pipe. This makes it easy to access the pump, thermal valve and check valve for service.

In the event of the Laddomat 22 malfunction or if the system has been bled, it is necessary to clean it from any dirt, such as lint, sealing tape, thread swarf, etc.

When reassembling, always clean all sealing surfaces.

1. Thermostatic valve
2. Self-circulation check valve
3. Pump impeller

In some systems, there is an extreme amount of contaminants that can cause clogging of the pump impeller, which may result in its putting out of operation.

In such a case dismount the rotor and clean the pump in accordance with the manufacturer's instructions.

## Pump settings in boiler circuit for Laddomat 22

Pump  
WILO Yonos PARA  
MS/ 7,5 - RKC W M

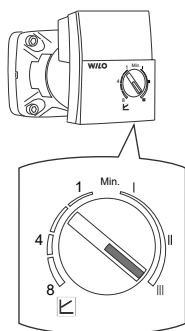

Pump  
WILO Para  
Para MS /8-75/SC

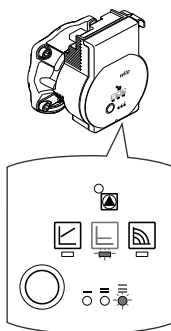

Prescribed pump setting in the boiler circuit  
- to maximum and constant displacement height  
We recommend not to change it

**INFO - the pumps are mutually interchangeable.**

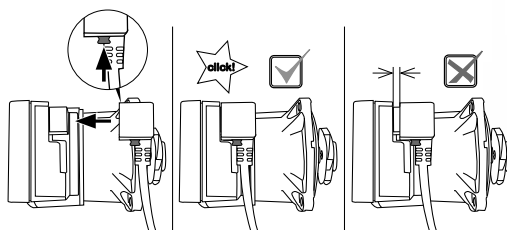

## RADIATOR SYSTEM

To make the maximum use of the storage tanks, it is important that the radiator system is fitted with:

1. Automatically controlled mixing valves.
2. Thermostatic valves with adjustable aperture, which is set to suit the radiator size.

Both solutions are intended to reduce the flow and so reduce the return temperature from the radiators circuit - as far as possible without raising the delivery temperature into the radiators circuit.

**The lower the return temperature, the longer the heat accumulated in the tanks lasts.**

## TECHNICAL DATA - LADDOMAT 22

Pump: WILO Yonos PARA MS/ 7,5 - RKC W M  
WILO Para MS /8-75/SC

Connection: R32 / 5/4" (with lever)

Opening temperature: 78 °C (standard (1456))

72 °C (included (8719))

57 °C, 63 °C or 83 °C on order

Max. boiler output: 50 kW (recommended)

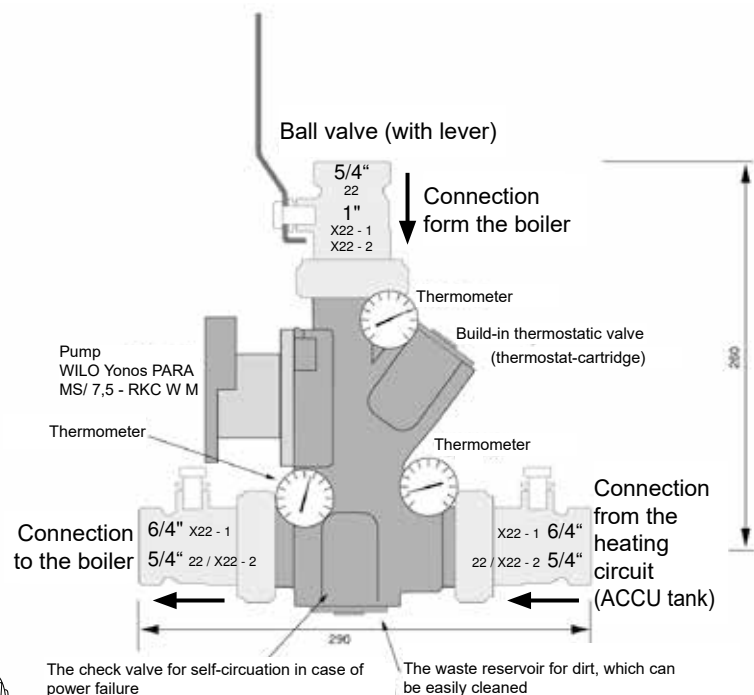

# Laddomat 22<sup>®</sup> Laddningspaket

## User Manual

### The Laddomat 22 has the following functions:

- To ensure that the boiler quickly reaches the operating temperature after firing.
- To charge the storage tanks to a high temperature with a low flow rate to achieve optimum layering in the tank.
- To transfer the residual heat from boiler to tank on termination of heating.
- When a power failure occurs and the circulation pump stops, to partially divert the excess heat via the check valve from boiler to tank or using the self-circulation system.

### Description of functions

#### Firing

For the boiler to achieve quickly a high operating temperature, the circulation pump must be started as soon as possible. This will prevent the boiler from being cooled down unnecessarily from cold water from the storage tank (system) due to a self-circulation.

Quick heating of the boiler to the operating temperature is desirable in order to reach a high efficiency and a low production of tar.

#### Start-up of the pump according to the flue gas temperature

The pump starts and stops by the flue thermostat that may be integrated in the boiler. The pump will switch on at the boiler (exhaust fan) start-up. CAUTION! The flue thermostat is not included in the Laddomat 22 delivery.

#### Start-up of the pump according to the water temperature

The pump starts by the thermostat located at the output of the boiler or by the thermostat built in the boiler at the water temperature of about 70 - 80 °C. This method of switching on the pump is used especially when connecting a boiler without storage tanks.

### Operation

The Laddomat 22 works fully automatically, provided that start and stop of the circulation pump is automated.

Settings, which are described below, are normally carried out only once.

The Laddomat does not require any special attention or service.

### Charging of the storage tank

The pump in the Laddomat 22 causes the water circulation in the boiler circuit via bypass and thermostatic valve. The thermostat cartridge in the thermostatic valve keeps the passage to the boiler return closed until the water temperature is below 78 °C.

The pump creates an overpressure during operation, which closes the check valve allowing a self-circulation of water.

When the desired water temperature of 78 °C (72 °C) to open the thermostatic valve is achieved, the thermostatic valve partially opens and water is sucked from the bottom of the tank.

The same quantity of the hot water is released slowly to the top of the tank. This provides a sharp border between the hot and cold water in the tank.

This border moves down as the charging continues until the tank is fully accumulated to the desired temperature. During the final phase of the charging of the storage tank the bypass passage in the Laddomat 22 is closed completely. All the water is then circulated from boiler to tank and thus the accumulation is accomplished.

### Settings

The temperature of the water returning to the boiler varies from 60 °C to 78 °C, depending on the type of the thermostat cartridge. The higher the thermostat cartridge temperature is set, the higher is the temperature of water in the return pipe to the boiler.

## Water temperature at top of the tank, the boiler output and flow through the boiler.

The water flow through the boiler can be adjusted by adjusting the pump speed by the knob of the circulation pump. Always start with the highest setting = 3 (maximum speed). A smaller flow through the boiler gives a higher charging temperature in the tank. The best result is achieved with the charging temperature of 80 - 95 °C.

Most boilers work best with the pump speed setting 2 or 3.

In case we want to achieve a higher or lower charging temperature than achieved by the standard thermostat cartridge, this cartridge can be easily replaced with another with the opening temperature of 72 °C, 83 °C or 88 °C.

**CAUTION! At boiler output exceeding 25 kW, do not forget always to choke (to 45°) the upper ball valve on the Laddomat 22.**

## Termination of the heating

If the Laddomat 22 is controlled by the flue thermostat, the circulation pump will stop after the fuel burns out.

The advantage of the rapid switching off of the pump after burning out of the fuel in the boiler is that cold water from the return circuit of radiators

gets to the bottom of the boiler due to gravitation and thus the residual heat from the boiler passes to accumulation. Thereby it is fully utilized for heating of the building.

To ensure the stopping of the circulation pump automatically or manually after the extinction of the boiler is still important for another reason.

The entire volume of accumulated 90 °C water in the tank would be mixed with cold water from radiators until the temperature of 75 °C is reached, when the thermostatic valve in the Laddomat 22 would close.

## Self-circulation

In the event of a power failure during the heating, the self-circulation starts to run automatically thanks to the check valve.

When the storage tank is fully charged (up to the bottom), the self-circulation is slight and the boiler may start to "cook".

In case of a prolonged power failure the whole house may be heated thanks to the self-circulation, if allowed by the distribution system of pipes and their diameters.

Then remember to adjust the output of the boiler so that the system can safely drain the developed heat.

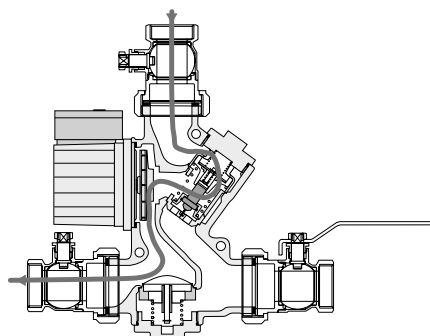

**Firing**

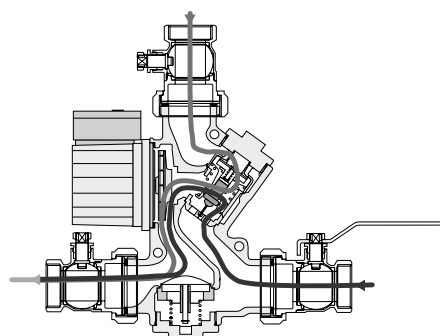

**Operation**

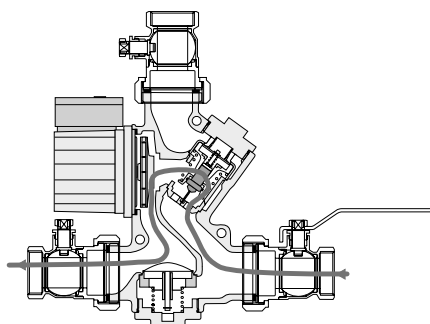

**Final phase**

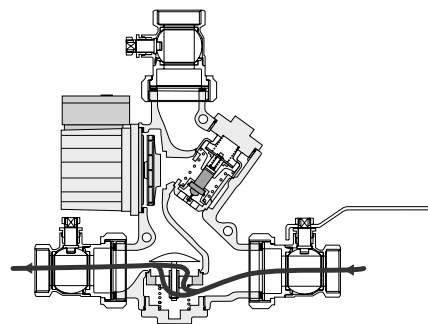

**Self-circulation**

# Important at the first start up

**The Laddomat 22 is factory-fitted with a thermostat No. 1456 which opens at 78 °C.**

The thermostat No. 8719 opening at 72 °C is included in the delivery (placed in the insulation of the Laddomat 22).

For most installations, best the thermostat 78 °C is proved. For boilers with a high output / low water content as well as at systems with long pipe lines / thin pipes, the thermostat opening at 72 °C may be preferred. The thermostat cartridge with the opening temperature of 72 °C should be used at outputs above 35 kW.

The higher charging temperature gives more accumulated heat. In addition, the losses in the boiler after the fuel burns out in the boiler with the thermostat having the opening temperature of 78 °C will be smaller, because the connection between boiler and storage tank will be interrupted sooner than with the use of thermostat having the opening temperature of 72 °C.

## Different amounts of air bubbles in the fresh water are present in all new systems.

This air releases inside the boiler walls after heating the water. The more the boiler heats up,

the more air bubbles are released. We therefore recommend heating the boiler to the highest temperature when starting it for the first time.

When the air released in such a way accumulates in the circulation pump, it can cause cessation of the circulation. At low temperatures the air releases more slowly and manages to be discharged through the expansion or venting.

## When a lot of air releases in the system, remove the thermostat cartridge for a short time.

In extreme cases it is appropriate to make some firings without use of the thermostat cartridge until the water is free of air. Remove the spring, plunger and thermostat cartridge and warm up the heating system with the upper shut-off valve closed.

## After the water is repeatedly heated to 85-95 °C and free of air, remount the thermostat cartridge into place.

If, despite these measures, there will be faults in the system operation, check whether lint or other debris are not in the pump preventing the circulation. Also check that the system is installed correctly according to the documentation.

## Instructions for replacing the thermostat in the Laddomat 22

Check that the circulation pump is switched off.

Close the three shut-off valves.

Unscrew the cover opposite the pump.

Remove the cover with spring, plunger and thermostat cartridge from the Laddomat 22 (Fig. 1). The thermostat cartridge is held in place on the plunger by an O-ring.

The thermostat cartridge can be easily removed from the plunger using a screwdriver (see Fig. 2).

Push a new thermostat cartridge into the plunger.

Reinstall all parts into place and tighten.

Open the shut-off valves.

Wait a few minutes before starting the pump to allow any air to rise and escape from the system.

The device is now ready for operation.

## Blocking the check valve

If you, for some reason, need to completely disconnect the self-circulation, the check valve must be blocked. The check valve is blocked using the blocking clip, which is located at the bottom of the EPP-insulation (Fig. 3), which is fastened around the check valve axis according to Fig. 4. To reach the axis, the spring needs to be removed.

Fig. 1

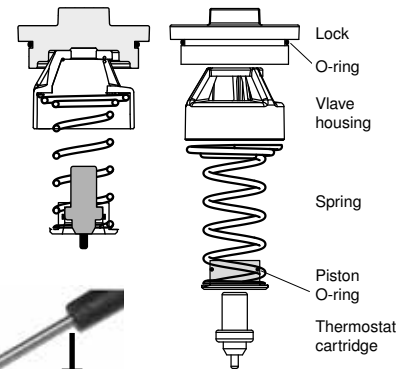

Fig. 2

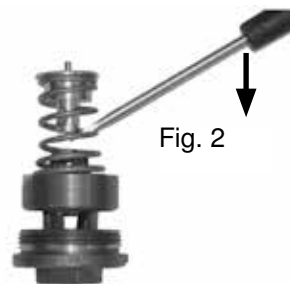
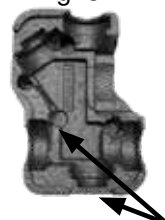
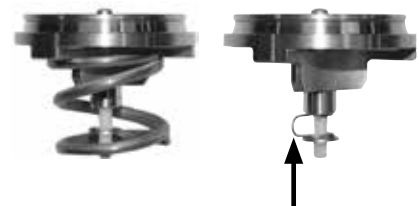

Fig. 3



Here there is a spare thermostat cartridge and blocking clip

Fig. 4



Blocking clip (check valve blocked)

# Connecting with one tank

When the pipe diameters are chosen properly and the shortest length is respected, then everything works OK, even at maximum heat consumption of the heated object. Good functionality and self-circulation are also guaranteed even in case of a power failure.

In this case, the recommended length of the pipe between boiler and tank is 2 m. The total length is then 2 + 2 m + 6 bends. The pressure loss of 1 bend corresponds to the pipe with a length of 1 m.

Boilers with a maximum output to:

80 kW min. Cu pipe 42x1.5 and/or R40  
100 (120) kW, minimum Cu pipe or 54x2 or R50

Flow:

With the above mentioned dimensions, the Laddomat 22 provides the flow of 3-4 m<sup>3</sup>/h. See the flow chart. For a longer piping the pipe diameter must be increased.

Max. distance between the boiler and tank is 6 m, it means that the total length is 6 + 6 m + 6 bends.

In case of special requirements for a self-circulation the pipe diameter is proposed according to these requirements.

Then charging temperature when connecting pipes for with output of 80-120 kW.

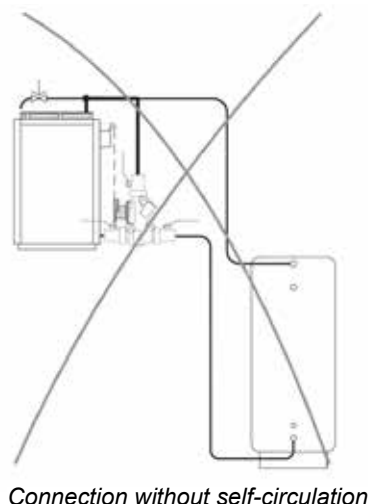
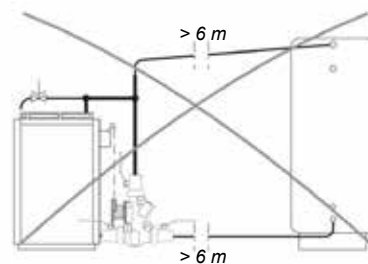
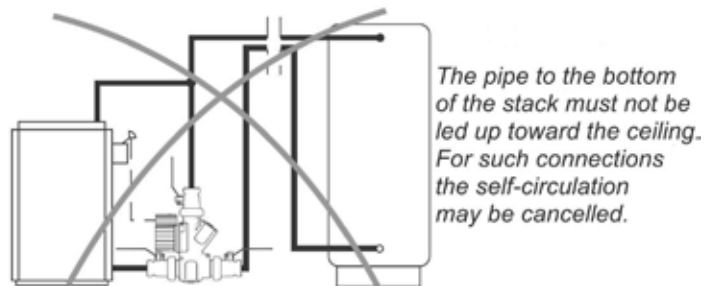
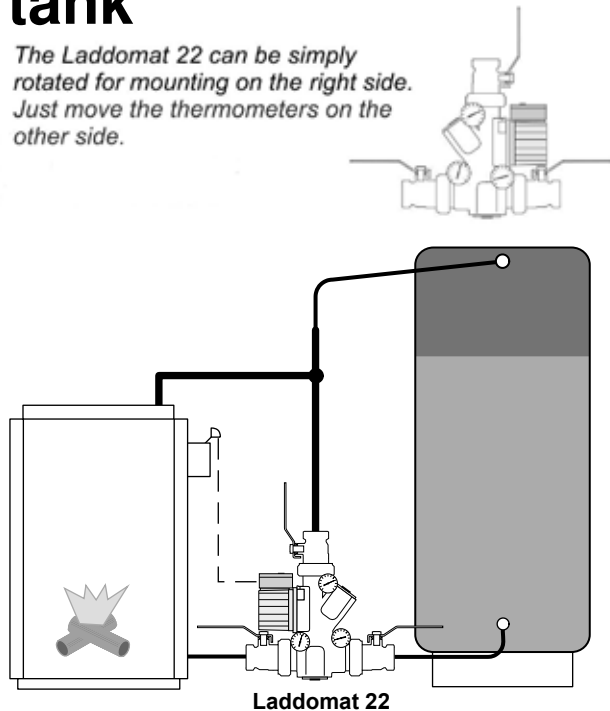
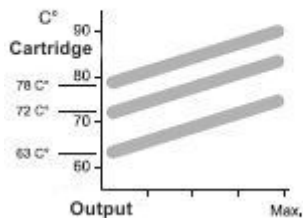

# Connecting 2-3 tanks

Tanks are always placed as close as possible to the boiler, next to each other. The piping distribution from the bottom of the tank is always carried out along the floor.

It is important that the flow into tanks during the charging and discharging is distributed evenly. When connected incorrectly, the charging will be interrupted after charging one tank before all tanks may be charged. The tanks are thus not fully exploited.

## The same length of pipes

To achieve the same resistance in the piping, the same length of the pipe distribution should be maintained for each tank as far as possible.

## 1. Specified connection of the boiler with the Laddomat 22

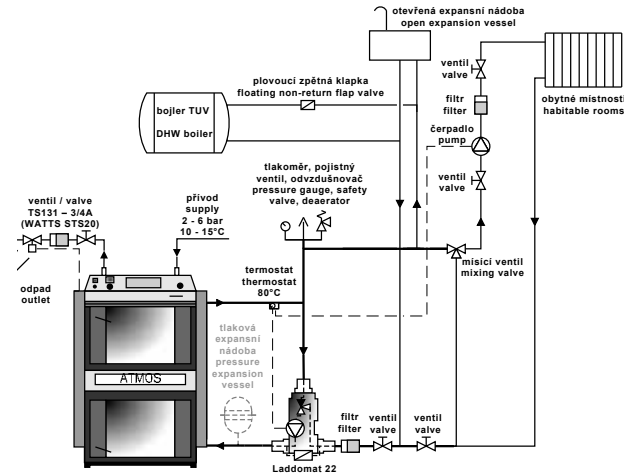

## 2. Specified boiler connection with the thermostatic valve

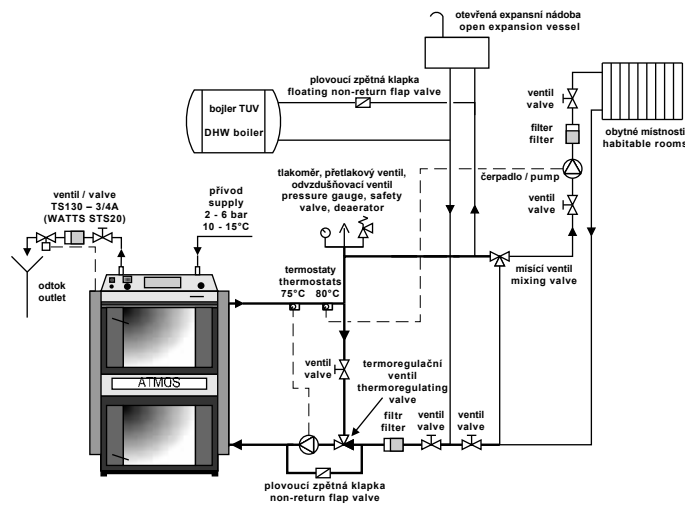

**ATTENTION-** when the cooling loop to prevent overheating is connected, the check valve on the bypass of pump and thermal valve may be omitted. In the case of placing the check valve on entry of water into the cooling loop to avoid a possible reverse flow of water due to a pressure drop in the water distribution system, the cooling loop must be fitted with a safety valve 6 to 10 bar or closed expansion vessel with a min. volume of 4 l.

## 3. Best specified boiler connection with the Laddomat 22 with storage tanks

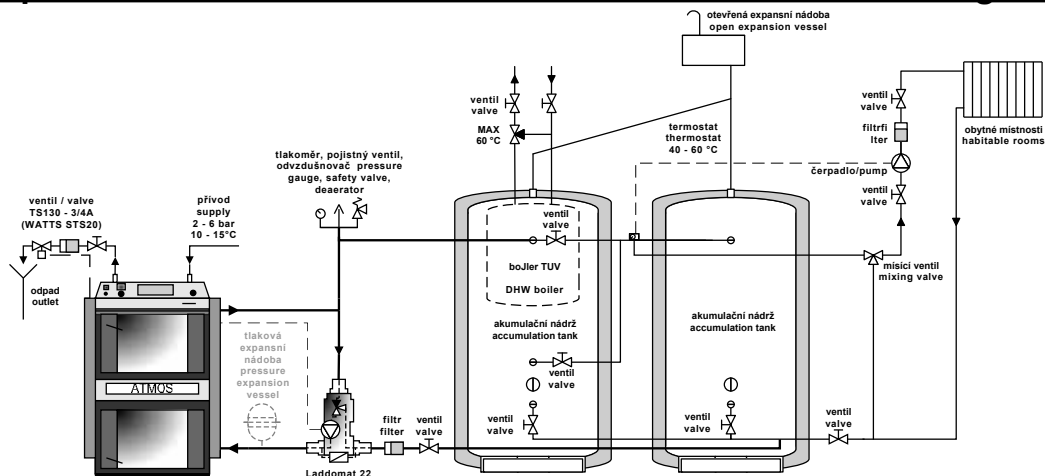

Boilers can be connected **with open or closed expansion vessel**. For the reason that the self-circulation of water extending the boiler start-up to the desired temperature between the boiler and the storage tanks works properly, connect the **flue thermostat** built in the boiler instead of the thermostat cartridge to switch on the pump in the boiler circuit. Thereby it is achieved that the boiler pump will switch on when the boiler starts up. This alternative is permissible only in the case of connecting the boiler with the Laddomat 22 or thermal valve TV 60 °C (65 °C).